



ENFRIADORES INDUSTRIALES DE AIRE



EFICIENTES, PODEROSOS Y CONFIABLES

Maxxicool línea Atlantis, ingeniería que combina eficiencia y confort, ideales para satisfacer las necesidades de enfriamiento de grandes áreas industriales y comerciales.

- Poleas de hierro vaciado.
- Uno o dos módulos húmedos con CELdek® importado, garantizado así la máxima eficiencia.
- Puerta abatible con cerradura para acceso al interior.
- Malla perforada en módulos húmedos que maximiza el flujo de aire.
- Turbina con capacidad certificada en laboratorio.
- Tubería interior de PVC con regulador para eficiente distribución de agua.
- Bomba sumergible en cada módulo húmedo.
- Flotador de bronce ajustable.

Con las versiones de **descarga horizontal, inferior y superior**, usted obtendrá gran capacidad y calidad de nivel internacional, logrando así una larga duración y máxima eficiencia real.

DIMENSIONES (pulgadas)

DESCARGA HORIZONTAL (H) Y SUPERIOR (S)

MODELO	MÓDULOS HÚMEDOS	A	B	C	D	E	F	G	H	I
ATLANTIS 300										
ATL-300/301 H	1	60	48	27	27 1/2	12 1/2	2	78	18	8
ATL-300/301 S						20 1/2				
ATL-302/303/305 H	2	96	48	27	27 1/2	12 1/2	2	60	18	8
ATL-302/303/305 S						20 1/2				
ATLANTIS 600										
ATL-603 H	1	96	60	31 1/8	31	31 5/8	2	78	18	14 3/4
ATL-603 S										
ATL-605/607/610 H	2	96	60	31 1/8	31	31 5/8	2	60	18	14 3/4
ATL-605/607/610 S										
ATLANTIS 900										
ATL-907/910/915/920 H	2	111 1/2	74 3/4	34	37 1/4	35 3/4	2	89	18	11 3/4
ATL-907/910/915/920 S						35				16 3/4
ATLANTIS 1200										
ATL-1215/1220/1225/1230 H	2	140	88	44 5/8	44 3/4	23 1/2	3	89	18	20 3/4
ATL-1215/1220/1225/1230 S						35 3/4				7 3/4
ATLANTIS 1500										
ATL-1507/1510/1515/1520 H	2	200 1/2	108	34 1/2	37 1/4	24	3	107	18	16 3/4
ATL-1507/1510/1515/1520 S						35				46 7/8
ATLANTIS 1800										
ATL-1815/1820/1825/1830 H	2	203	108	43	43 1/2	45 1/2	3	109	18	19 1/2
ATL-1815/1820/1825/1830 S						48 1/2				23

MODELOS 300, 301 Y 603

1 MÓDULO HÚMEDO

DESCARGA HORIZONTAL

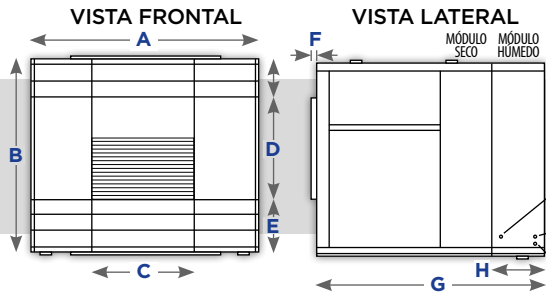

- 1.- Alimentación de agua, flotador con válvula de rosca de 1/2" de diámetro NPT (para tubo).
- 2.- Rebosadero cople 1/2" de diámetro NPT (para tubo).
- 3.- Drenaje de 1/2" de diámetro NPT (para tubo).

2 MÓDULOS HÚMEDOS

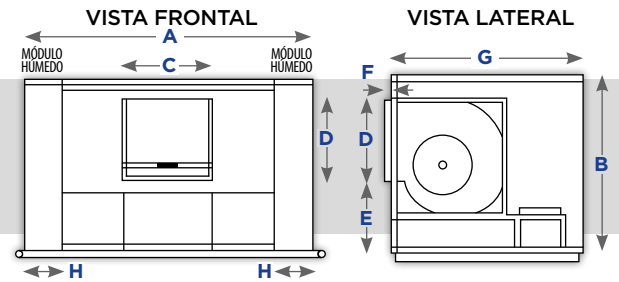

DESCARGA INFERIOR

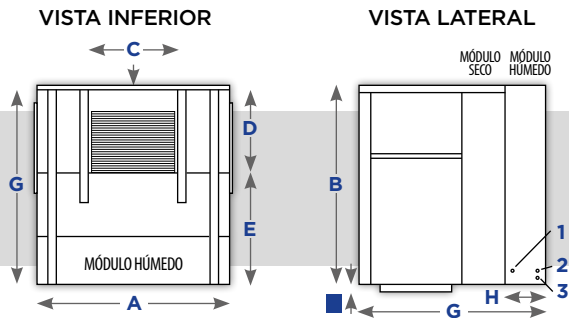

- 1.- Alimentación de agua, flotador con válvula de rosca de 1/2" de diámetro NPT (para tubo).
- 2.- Rebosadero cople 1/2" de diámetro NPT (para tubo).
- 3.- Drenaje de 1/2" de diámetro NPT (para tubo).

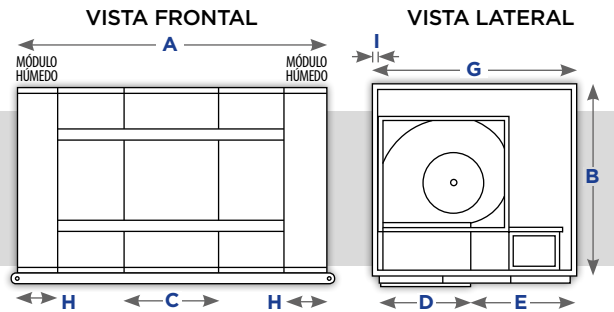

DESCARGA SUPERIOR

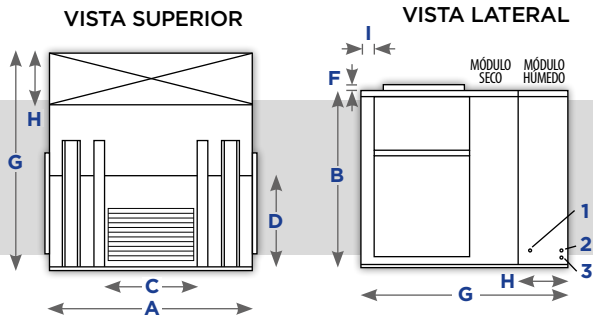

- 1.- Alimentación de agua, flotador con válvula de rosca de 1/2" de diámetro NPT (para tubo).
- 2.- Rebosadero cople 1/2" de diámetro NPT (para tubo).
- 3.- Drenaje de 1/2" de diámetro NPT (para tubo).

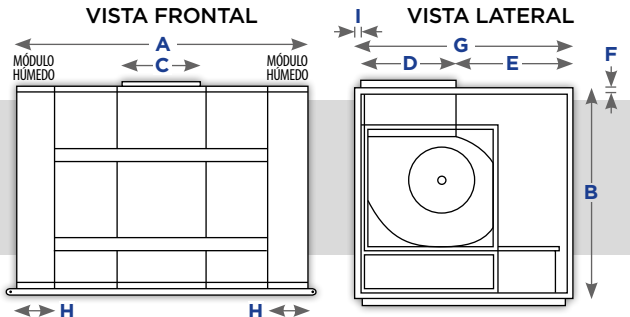

MODELOS 1500 y 1800

DOBLE TURBINA

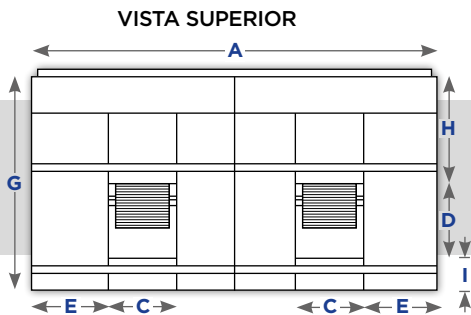

- 1.- Alimentación de agua, flotador con válvula de rosca de 1/2" de diámetro NPT (para tubo).
- 2.- Rebosadero cople 1/2" de diámetro NPT (para tubo).
- 3.- Drenaje de 1/2" de diámetro NPT (para tubo).

DESCARGA SUPERIOR

1 MÓDULO HÚMEDO

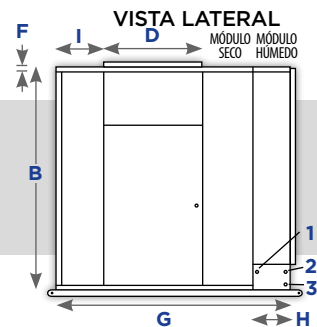

DESCARGA HORIZONTAL, INFERIOR Y SUPERIOR

MODELO	TURBINA				MÓDULO HÚMEDO		BANDAS	POLEAS		PESO	
	Diámetro	Ancho	Flacha	Cantidad	Pulgadas espesor/largo/alto	Número de módulos		Polea motriz	Polea volante	Transporte ¹ (kg)	Operación (kg)
ATLANTIS 300											
ATL-300	22"	22"	13/8"	1	12*60*36	1	2	4 X 7/8" V 2R	16 X 13/8" 2R	370	453
ATL-301	22"	22"	13/8"	1	12*60*36	1	2	4 X 7/8" V 2R	16 X 13/8" 2R	370	453
ATL-302	22"	22"	13/8"	1	12*60*36	2	2	4 X 7/8" V 2R	16 X 13/8" 2R	430	583
ATL-303	22"	22"	13/8"	1	12*60*36	2	2	4 X 7/8" V 2R	16 X 13/8" 2R	430	590.5
ATL-305	22"	22"	13/8"	1	12*60*36	2	2	4 1/2 X 1 1/8" V 2R	16 X 13/8" 2R	430	600
ATLANTIS 600											
ATL-603	25"	25"	13/8"	1	12*72*48	1	2	4 X 1 1/8" V 2R	16 X 13/8" 2R	520	617
ATL-605	25"	25"	13/8"	1	12*60*48	2	2	4 1/2 X 1 1/8" V 2R	16 X 13/8" 2R	600	779
ATL-607	25"	25"	13/8"	1	12*60*48	2	2	5 X 1 3/8" V 2R	16 X 13/8" 2R	600	788.5
ATL-610	25"	25"	13/8"	1	12*60*48	2	2	5 X 1 3/8" V 2R	16 X 13/8" 2R	600	798
ATLANTIS 900											
ATL-907	30"	28"	13/8"	1	12*84*60	2	3	5.9 X 1 3/8" V 3R	18 3/4 X 1 3/8" 3R	830	1279.5
ATL-910	30"	28"	13/8"	1	12*84*60	2	3	5.9 X 1 3/8" V 3R	18 3/4 X 1 3/8" 3R	830	1289
ATL-915	30"	28"	13/8"	1	12*84*60	2	3	5.9 X 1 5/8" V 3R	18 3/4 X 1 3/8" 3R	830	1324
ATL-920	30"	28"	13/8"	1	12*84*60	2	3	5.9 X 1 5/8" V 3R	18 3/4 X 1 3/8" 3R	830	1366
ATLANTIS 1200											
ATL-1215	36"	36"	2 1/4"	1	12*84*72	2	3	5.9 X 1 5/8" V 3R	25 X 2 1/4" 3R	1190	1728
ATL-1220	36"	36"	2 1/4"	1	12*84*72	2	3	5.9 X 1 5/8" V 3R	25 X 2 1/4" 3R	1190	1770
ATL-1225	36"	36"	2 1/4"	1	12*84*72	2	3	5.9 X 1 7/8" V 3R	25 X 2 1/4" 3R	1190	1825
ATL-1230	36"	36"	2 1/4"	1	12*84*72	2	3	5.9 X 1 7/8" V 3R	25 X 2 1/4" 3R	1190	1833.5
ATLANTIS 1500											
ATL-1507	30"	28"	13/8"	2	12*96 3/8" 192	1	6	5.9 X 1 5/8" V 3R	18 3/4 X 1 3/8" 3R	2200	3100
ATL-1510	30"	28"	13/8"	2	12*96 3/8" 192	1	6	5.9 X 1 5/8" V 3R	18 3/4 X 1 3/8" 3R	2200	3118
ATL-1515	30"	28"	13/8"	2	12*96 3/8" 192	1	6	5.9 X 1 5/8" V 3R	18 3/4 X 1 3/8" 3R	2200	3190
ATL-1520	30"	28"	13/8"	2	12*96 3/8" 192	1	6	5.9 X 1 5/8" V 3R	18 3/4 X 1 3/8" 3R	2200	3275
ATLANTIS 1800											
ATL-1815	36"	36"	2 1/4"	2	12*86" 192	1	6	5.9 X 1 5/8" V 3R	30 X 2 1/4" 3R	2550	3625
ATL-1820	36"	36"	2 1/4"	2	12*86" 192	1	6	5.9 X 1 5/8" V 3R	30 X 2 1/4" 3R	2550	3710
ATL-1825	36"	36"	2 1/4"	2	12*86" 192	1	6	5.9 X 1 7/8" V 3R	30 X 2 1/4" 3R	2550	3820
ATL-1830	36"	36"	2 1/4"	2	12*86" 192	1	6	5.9 X 1 7/8" V 3R	30 X 2 1/4" 3R	2550	3850

MOTOR Y BOMBA

MODELO	MOTOR						BOMBA					
	H.P.	Volt.	Amp.	Hertz	Fases	Peso motor	Volt.	Amp.	Hertz	H.P.	Gasto	Cantidad
ATLANTIS 300												
ATL-300	1	220/440	3.3/1.3	60	3	15 kg	115	5	60	1/6	18 Gal./min	1
ATL-301	1.5	220/440	5.1/2.0	60	3	15 kg	115	5	60	1/6	18 Gal./min	1
ATL-302	2	220/440	7.5/3.0	60	3	17 kg	115	5	60	1/6	18 Gal./min	2
ATL-303	3	220/440	7.99/3.2	60	3	24.5 kg	115	5	60	1/6	18 Gal./min	2
ATL-305	5	220/440	13.9/5.5	60	3	34 kg	115	5	60	1/6	18 Gal./min	2
ATLANTIS 600												
ATL-603	3	220/440	13.9/5.5	60	3	24.5 kg	115	5	60	1/6	18 Gal./min	1
ATL-605	5	220/440	13.9/5.5	60	3	34 kg	115	5	60	1/6	18 Gal./min	2
ATL-607	7.5	220/440	19.5/7.8	60	3	43.5 kg	115	5	60	1/6	18 Gal./min	2
ATL-610	10	220/440	25.8/10.3	60	3	53 kg	115	5	60	1/6	18 Gal./min	2
ATLANTIS 900												
ATL-907	7.5	220/440	25.8/10.3	60	3	43.5 kg	115	5	60	1/6	18 Gal./min	2
ATL-910	10	220/440	25.8/10.3	60	3	53 kg	115	5	60	1/6	18 Gal./min	2
ATL-915	15	220/440	37.1/14.8	60	3	88 kg	115	5	60	1/6	18 Gal./min	2
ATL-920	20	220/440	48.1/19.2	60	3	130 kg	115	5	60	1/6	18 Gal./min	2
ATLANTIS 1200												
ATL-1215	15	220/440	48.1/19.2	60	3	88 kg	115	5	60	1/6	18 Gal./min	2
ATL-1220	20	220/440	48.1/19.2	60	3	130 kg	115	5	60	1/6	18 Gal./min	2
ATL-1225	25	220/440	60.4/24.2	60	3	185 kg	115	5	60	1/6	18 Gal./min	2
ATL-1230	30	220/440	81.4/32.6	60	3	193.5 kg	115	5	60	1/6	18 Gal./min	2
ATLANTIS 1500												
ATL-1507	7.5	220/440	81.4/32.6	60	3	43.5 kg	115	5	60	1/6	18 Gal./min	2
ATL-1510	10	220/440	81.4/32.6	60	3	53 kg	115	5	60	1/6	18 Gal./min	2
ATL-1515	15	220/440	81.4/32.6	60	3	88 kg	115	5	60	1/6	18 Gal./min	2
ATL-1520	20	220/440	81.4/32.6	60	3	130 kg	115	5	60	1/6	18 Gal./min	2
ATLANTIS 1800												
ATL-1815	15	220/440	81.4/32.6	60	3	88 kg	115	5	60	1/6	18 Gal./min	2
ATL-1820	20	220/440	81.4/32.6	60	3	130 kg	115	5	60	1/6	18 Gal./min	2
ATL-1825	25	220/440	81.4/32.6	60	3	185 kg	115	5	60	1/6	18 Gal./min	2
ATL-1830	30	220/440	81.4/32.6	60	3	193.5 kg	115	5	60	1/6	18 Gal./min	2

ENTREGA DE AIRE v.s. PRESIÓN ESTÁTICA Caída de presión (pulgada por columna de agua)

■ **ÁREA SOMBRADA = NIVEL DE MÁXIMA EFICIENCIA**

NR = NO RECOMENDABLE

ATLANTIS 300												
MODELO	0		0.2		0.4		0.5		0.6		0.8	
	PCM	RPM	PCM	RPM	PCM	RPM	PCM	RPM	PCM	RPM	PCM	RPM
300	8100	280	7700	300	7400	330	6500	345	6000	365	4700	430
301	10600	300	9800	320	9000	355	8500	365	7700	385	6500	420
302	11600	330	10900	355	10500	380	9900	390	9400	400	8300	430
303	13100	350	12500	390	12200	405	12000	425	11600	430	10500	465
305	16800	360	16200	400	15800	435	15200	470	14400	505	13400	510
MODELO	1		1.2		1.4		1.6		1.8		2	
	PCM	RPM	PCM	RPM	PCM	RPM	PCM	RPM	PCM	RPM	PCM	RPM
300												
301	5800	470	4700	527	3400	600						
302	7300	470	6200	520	5500	560	4800	600	4100	640	3700	680
303	9700	490	8300	525	7900	560	7200	590	6600	645	6100	680
305	13100	530	12500	560	11900	580	10800	600	10200	640	9500	660

ATLANTIS 600												
MODELO	0		0.2		0.4		0.5		0.6		0.8	
	PCM	RPM	PCM	RPM	PCM	RPM	PCM	RPM	PCM	RPM	PCM	RPM
603	16500	290	15200	305	13900	340	13400	350	12800	370	12000	395
605	19500	280	19000	300	18000	335	17400	370	17100	405	16400	440
607	23500	390	22900	400	21100	425	20900	430	19700	450	19100	475
610	24800	435	24100	445	23300	465	22900	475	22200	485	21900	500
MODELO	1		1.2		1.4		1.6		1.8		2	
	PCM	RPM	PCM	RPM	PCM	RPM	PCM	RPM	PCM	RPM	PCM	RPM
603	11000	420	9800	455	9000	490	7100	540	6700	570	5800	600
605	16000	450	14200	480	13100	500	12100	580	11200	555	10200	600
607	18500	495	17500	520	17100	535	16600	555	15900	575	15300	590
610	21400	515	20300	535	19500	555	19300	575	18300	595	17600	610

ATLANTIS 900												
MODELO	0.5		0.75		1		1.25		1.5		1.75	
	PCM	RPM	PCM	RPM	PCM	RPM	PCM	RPM	PCM	RPM	PCM	RPM
907	25400	305	24500	335	22900	355	21000	380	18800	405	17200	440
910	28100	335	26800	345	25500	370	24800	395	23700	425	22300	445
915	33000	345	32400	390	31800	400	29900	420	27800	440	26700	460
920	40600	400	40100	440	37500	445	36200	455	34400	465	33100	490
MODELO	2		2.25		2.5		2.75		3		3.25	
	PCM	RPM	PCM	RPM	PCM	RPM	PCM	RPM	PCM	RPM	PCM	RPM
907	15900	470	12800	500	13100	530	12100	555	10700	580	10200	600
910	20000	475	18500	500	17400	530	15900	555	14900	580	13700	605
915	25400	485	24500	505	23250	535	21600	550	20700	580	19250	605
920	31900	555	29900	525	28650	545	27350	560	26050	580	25200	600

ATLANTIS 1200												
MODELO	0.5		0.75		1		1.25		1.5		1.75	
	PCM	RPM	PCM	RPM	PCM	RPM	PCM	RPM	PCM	RPM	PCM	RPM
1215	40500	295	38000	315	36000	325	34000	350	33000	360	31000	370
1220	44500	320	42500	338	41000	350	40000	375	38000	375	37000	395
1225	48500	340	47000	352	45000	370	43500	380	42100	390	41000	406
1230	NR	NR	NR	NR	49000	380	48000	400	46000	406	45000	415
MODELO	2		2.25		2.5		2.75		3		3.25	
	PCM	RPM	PCM	RPM	PCM	RPM	PCM	RPM	PCM	RPM	PCM	RPM
1215	29500	390	27000	410	25000	445	22000	460	16000	525	10000	570
1220	35200	408	33000	420	32000	440	30000	460	28000	470	21000	552
1225	39000	420	38000	435	37000	445	35500	465	34000	475	31000	520
1230	43200	435	41000	450	40900	460	39800	470	38000	483	35000	520

ATLANTIS 1500												
MODELO	0.5		0.75		1		1.25		1.5		1.75	
	PCM	RPM	PCM	RPM	PCM	RPM	PCM	RPM	PCM	RPM	PCM	RPM
1507	50800	305	49000	335	45800	355	42000	380	37600	405	34400	440
1510	56200	335	53600	345	51000	370	49600	395	47400	425	44600	445
1515	66000	345	64800	390	63600	400	59800	420	55600	440	53400	460
1520	83800	400	80200	440	75000	445	72400	455	68800	465	66200	490
MODELO	2		2.25		2.5		2.75		3		3.25	
	PCM	RPM	PCM	RPM	PCM	RPM	PCM	RPM	PCM	RPM	PCM	RPM
1507	31800	470	25600	500	26200	530	24200	555	21400	580	20400	600
1510	40000	475	37000	500	34800	530	31800	555	28800	580	27400	605
1515	50800	485	49000	505	46500	535	43200	550	41400	580	38500	605
1520	63800	555	59800	525	57300	545	54700	560	52100	580	50400	600

ATLANTIS 1800												
MODELO	0.5		0.75		1		1.25		1.5		1.75	
	PCM	RPM	PCM	RPM	PCM	RPM	PCM	RPM	PCM	RPM	PCM	RPM
1815	81000	295	76000	315	72000	325	68000	350	66000	360	62000	370
1820	89000	320	85000	338	82000	350	80000	375	74000	375	74000	395
1825	97000	340	84000	352	90000	370	87000	380	82000	390	82000	406
1830	NR	NR	NR	NR	98000	380	96000	400	92800	406	90000	415
MODELO	2		2.25		2.5		2.75		3		3.25	
	PCM	RPM	PCM	RPM	PCM	RPM	PCM	RPM	PCM	RPM	PCM	RPM
1815	59000	390	54000	410	50000	445	44000	460	32000	525	20000	570
1820	70400	408	66000	420	64000	440	60000	460	56000	470	42000	552
1825	78000	420	76000	436	74000	445	71000	465	68000	475	62000	520
1830	86400	436	82000	450	81800	460	79600	470	76000	483	70000	520

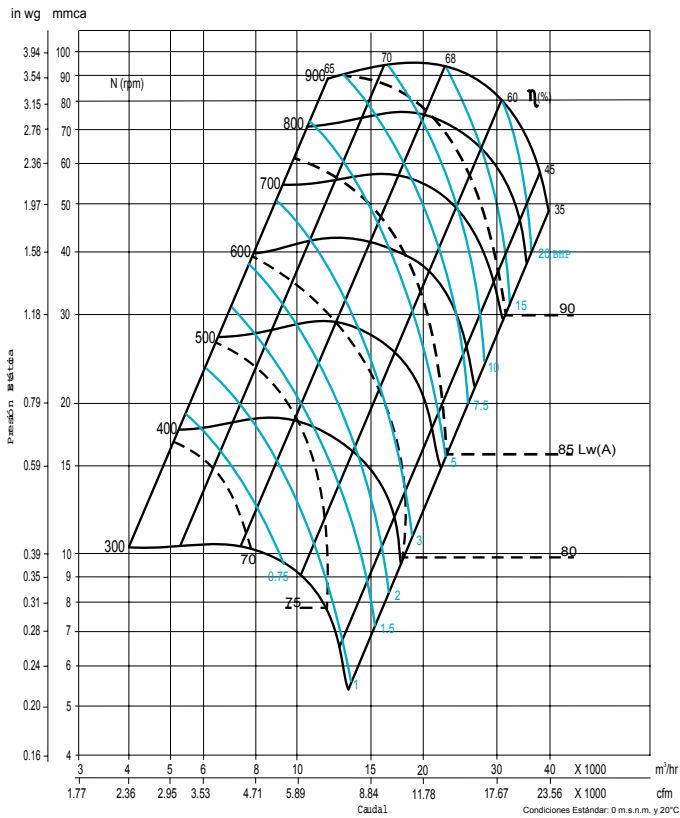

ATLANTIS 300
TURBINA 22" X 22"

ATLANTIS 600
TURBINA 25" X 25"

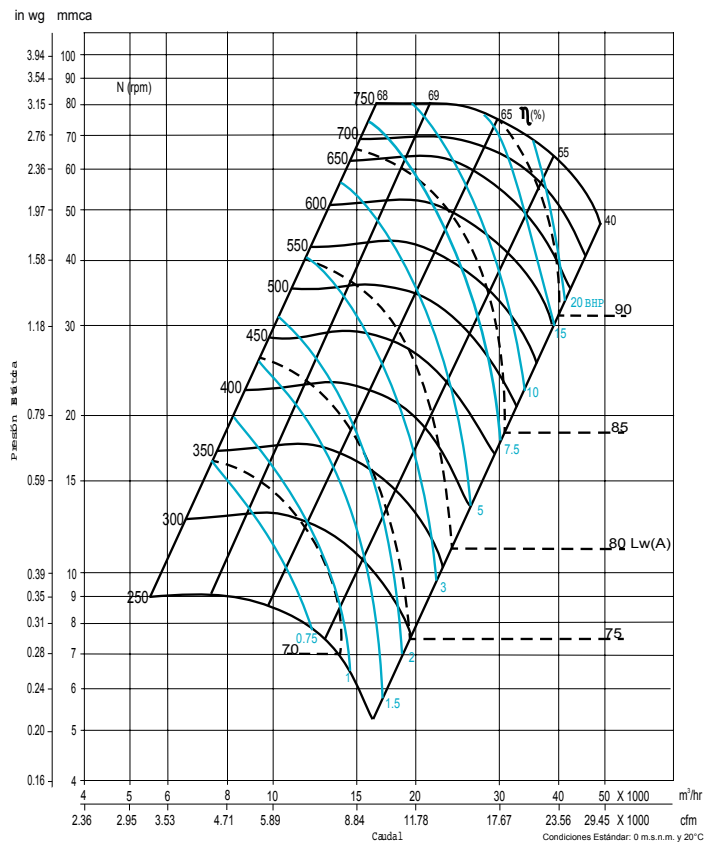

in wg mmca

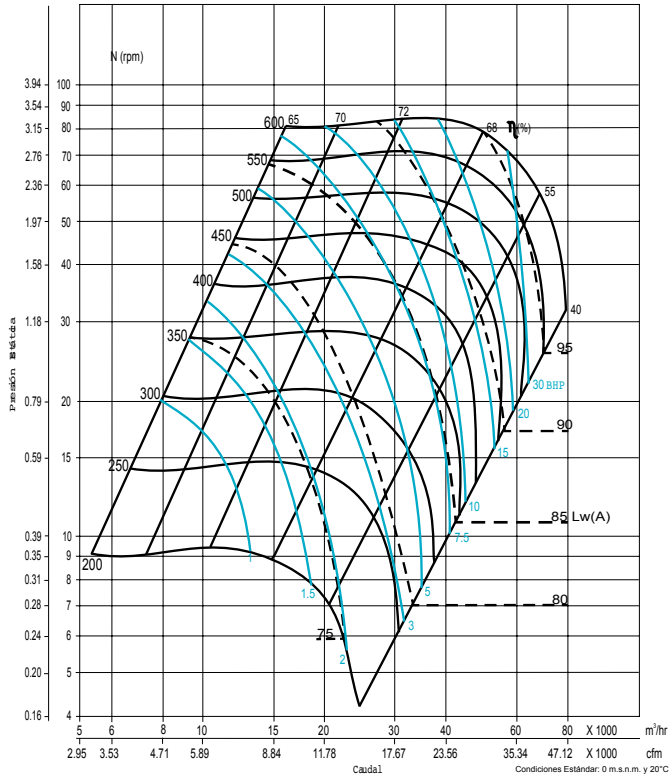

ATLANTIS 900, 1500

TURBINA 30" X 28"

ATLANTIS 1200, 1800

TURBINA 36" X 36"

in wg mmca

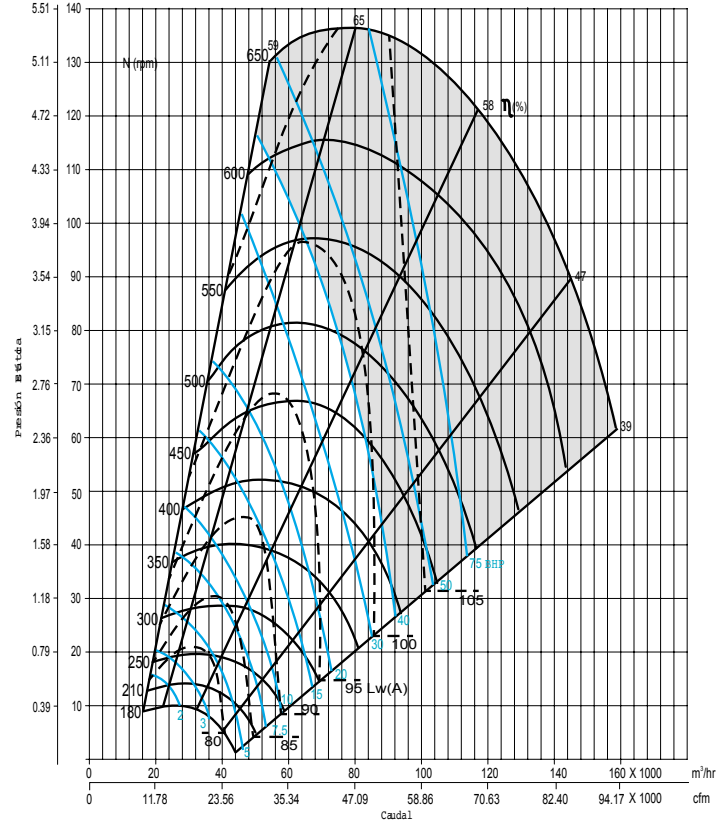



SERVICIO AUTORIZADO MACON
(871) 759-0101
sam@imacon.com

2016/07